

Boston Insurance Specialists, Inc.
 800 South Main Street, Suite 101
 Mansfield, MA 02048
 Tel: 800-784-1887 Fax: 508-337-3698 –
WOOD/COAL BURNING FACILITY
QUESTIONNAIRE

Policy No.: _____
 Insured: _____
 Agent: _____
 Location of Risk: _____

REQUIREMENTS

1. A photo of the wood/coal burning facility must be submitted with this Questionnaire.
2. Questionnaire and photo must be submitted with application for insurance.
3. Questionnaire must be inspected and signed by a licensed contractor or member of local fire department when facility is NOT factory installed or commercially installed by appliance distributor or licensed expert.

STOVE INFORMATION

| | |
|--|--|
| TYPE | <input type="checkbox"/> Radiant <input type="checkbox"/> Circulating <input type="checkbox"/> Franklin <input type="checkbox"/> Other (specify): |
| MAKE/NAME | By: _____ U.L. Approved?..... <input type="checkbox"/> Yes <input type="checkbox"/> No |
| USE | <input type="checkbox"/> Primary Heat <input type="checkbox"/> Auxiliary Heat <input type="checkbox"/> Cooking <input type="checkbox"/> Other (specify): |
| INSTALLED | By: _____ Date: _____ |
| FLOOR PROTECTION | <input type="checkbox"/> Asbestos Millboard Covered with Metal <input type="checkbox"/> Metal <input type="checkbox"/> Stone/Brick <input type="checkbox"/> Other (specify below) |
| WALL PROTECTION | <input type="checkbox"/> Asbestos Millboard Covered with Metal <input type="checkbox"/> Metal <input type="checkbox"/> Asb. Millbrd <input type="checkbox"/> Other (specify below) |
| CHIMNEY & STOVE PIPES | CHIMNEY TYPE: <input type="checkbox"/> Factory <input type="checkbox"/> Masonry <input type="checkbox"/> Other (describe): |
| | How often checked for creosote build-up? |
| | Date Last Cleaned: _____ By Whom? _____ |
| | Does vent pass through a combustible partition?..... <input type="checkbox"/> Yes <input type="checkbox"/> No |
| | If yes, is protection thimble or sleeve used?..... <input type="checkbox"/> Yes <input type="checkbox"/> No |
| | Does pipe vent pass directly through the roof? <input type="checkbox"/> Yes <input type="checkbox"/> No |
| | Are any other heating units vented to chimney?..... <input type="checkbox"/> Yes <input type="checkbox"/> No (describe below) |
| Is stove vent system equipped with heat reclaiming unit or flue radiator? <input type="checkbox"/> Yes <input type="checkbox"/> No | |

CLEARANCES

1. Side of unit to nearest wall inches.
 2. Rear of unit to wall inches.
 3. Top of stovepipe to ceiling inches.
 4. Bottom of unit to floor inches.
 5. Front of unit to front edge of floor protection inches.
 6. Size of stovepipe used inches.
 7. Size of thimble or roof joist shield inches.
- Do these distances comply with the manufacturer's standards?..... Yes No

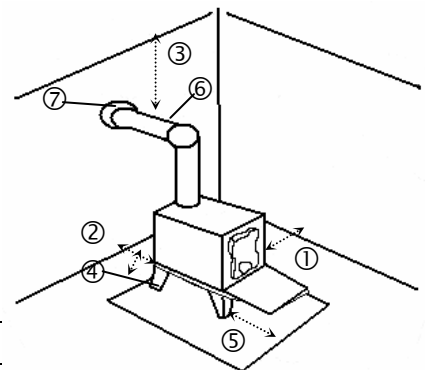

MISCELLANEOUS

| | |
|--------------------|---|
| FUEL | <input type="checkbox"/> Wood <input type="checkbox"/> Coal <input type="checkbox"/> Other (specify): |
| PREVENTION | Fire Extinguisher in Room?..... <input type="checkbox"/> Yes <input type="checkbox"/> No Smoke Alarm? <input type="checkbox"/> Yes <input type="checkbox"/> No |
| ADDITIONAL REMARKS | |

Inspector Signature: _____ Date Inspected: _____

PHOTO MUST BE ATTACHED